

# 101 Models Electromagnetic Clutches - Flange-mounted Type

## Specifications

Model	Size	Dynamic friction torque T <sub>d</sub> [N·m]	Static friction torque T <sub>s</sub> [N·m]	Coil (at 20°C)					Heat resistance Class	Lead wire		Max. rotation speed [min <sup>-1</sup> ]	Rotating part moment of inertia J		Total work performed until readjustment of the air gap E <sub>r</sub> [J]	Armature pull-in time t <sub>a</sub> [s]	Torque build-up time t <sub>p</sub> [s]	Torque decaying time t <sub>d</sub> [s]	Mass [kg]
				Voltage [V]	Wattage [W]	Current [A]	Resistance [Ω]	UL style		Size	Rotor [kg·m <sup>2</sup> ]		Armature [kg·m <sup>2</sup> ]						
101-06-13G													4.23 × 10 <sup>-5</sup>						0.46
101-06-15G	06	5	5.5	DC24	11	0.46	52	B	UL3398	AWG22	8000	7.35 × 10 <sup>-5</sup>	1.05 × 10 <sup>-4</sup>	36 × 10 <sup>6</sup>	0.020	0.041	0.020	0.66	
101-06-11G													6.03 × 10 <sup>-5</sup>					0.5	
101-08-13G													1.18 × 10 <sup>-4</sup>					0.83	
101-08-15G	08	10	11	DC24	15	0.63	38	B	UL3398	AWG18	6000	2.24 × 10 <sup>-4</sup>	3.00 × 10 <sup>-4</sup>	60 × 10 <sup>6</sup>	0.023	0.051	0.030	1.19	
101-08-11G													1.71 × 10 <sup>-4</sup>					0.91	
101-10-13G													4.78 × 10 <sup>-4</sup>					1.5	
101-10-15G	10	20	22	DC24	20	0.83	29	B	UL3398	AWG18	5000	6.78 × 10 <sup>-4</sup>	9.45 × 10 <sup>-4</sup>	130 × 10 <sup>6</sup>	0.025	0.063	0.050	2.11	
101-10-11G													6.63 × 10 <sup>-4</sup>					1.66	
101-12-13G													1.31 × 10 <sup>-3</sup>					2.76	
101-12-15G	12	40	45	DC24	25	1.04	23	B	UL3398	AWG18	4000	2.14 × 10 <sup>-3</sup>	2.75 × 10 <sup>-3</sup>	250 × 10 <sup>6</sup>	0.040	0.115	0.065	3.8	
101-12-11G													1.81 × 10 <sup>-3</sup>					3.05	
101-16-13G													4.80 × 10 <sup>-3</sup>					5.1	
101-16-15G	16	80	90	DC24	35	1.46	16	B	UL3398	AWG18	3000	6.30 × 10 <sup>-3</sup>	9.05 × 10 <sup>-3</sup>	470 × 10 <sup>6</sup>	0.050	0.160	0.085	6.9	
101-16-11G													6.35 × 10 <sup>-3</sup>					5.4	
101-20-13G													1.37 × 10 <sup>-2</sup>					9.3	
101-20-15G	20	160	175	DC24	45	1.88	13	B	UL3398	AWG16	2500	1.93 × 10 <sup>-2</sup>	2.65 × 10 <sup>-2</sup>	10 × 10 <sup>8</sup>	0.090	0.250	0.130	13	
101-20-11G													1.90 × 10 <sup>-2</sup>					10.5	
101-25-13G													3.58 × 10 <sup>-2</sup>					17	
101-25-15G	25	320	350	DC24	60	2.5	9.6	B	UL3398	AWG16	2000	4.48 × 10 <sup>-2</sup>	7.45 × 10 <sup>-2</sup>	20 × 10 <sup>8</sup>	0.115	0.335	0.210	23.6	
101-25-11G													4.83 × 10 <sup>-2</sup>					18.7	

\* The dynamic friction torque, T<sub>d</sub>, is measured at a relative speed of 100 min<sup>-1</sup>. Depending on the initial torque characteristics, break-in to condition the engaging surfaces may also be required.  
 \* The rotating part moment of inertia and mass are measured for the maximum bore diameter.

## Dimensions (101-□-13G)

(For direct mounting)

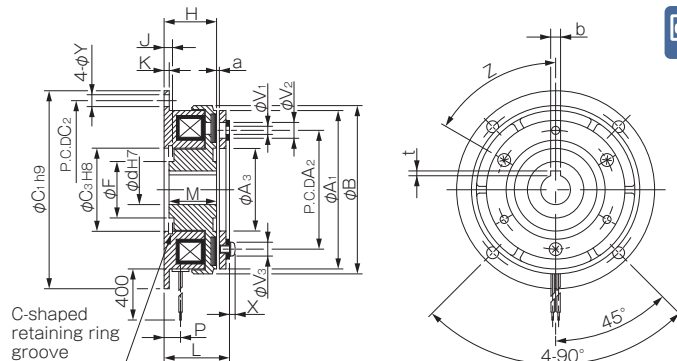

Unit [mm]

Size	Shaft bore dimensions				
	d	Models compliant with JIS standards		Models compliant with the old JIS standards	
		b P9	t	b E9	t
06	12	4 <sup>-0.012</sup> <sub>-0.042</sub>	1.5 <sup>+0.05</sup> <sub>0</sub>	4 <sup>+0.050</sup> <sub>+0.020</sub>	1.5 <sup>+0.5</sup> <sub>0</sub>
	15	5 <sup>-0.012</sup> <sub>-0.042</sub>	2 <sup>+0.05</sup> <sub>0</sub>	5 <sup>+0.050</sup> <sub>+0.020</sub>	2 <sup>+0.5</sup> <sub>0</sub>
08	15	5 <sup>-0.012</sup> <sub>-0.042</sub>	2 <sup>+0.05</sup> <sub>0</sub>	5 <sup>+0.050</sup> <sub>+0.020</sub>	2 <sup>+0.5</sup> <sub>0</sub>
	20	6 <sup>-0.012</sup> <sub>-0.042</sub>	2.5 <sup>+0.05</sup> <sub>0</sub>	5 <sup>+0.050</sup> <sub>+0.020</sub>	2 <sup>+0.5</sup> <sub>0</sub>
10	20	6 <sup>-0.012</sup> <sub>-0.042</sub>	2.5 <sup>+0.05</sup> <sub>0</sub>	5 <sup>+0.050</sup> <sub>+0.020</sub>	2 <sup>+0.5</sup> <sub>0</sub>
	25	8 <sup>-0.015</sup> <sub>-0.051</sub>	3 <sup>+0.05</sup> <sub>0</sub>	7 <sup>+0.061</sup> <sub>+0.025</sub>	3 <sup>+0.5</sup> <sub>0</sub>
12	25	8 <sup>-0.015</sup> <sub>-0.051</sub>	3 <sup>+0.05</sup> <sub>0</sub>	7 <sup>+0.061</sup> <sub>+0.025</sub>	3 <sup>+0.5</sup> <sub>0</sub>
	30	8 <sup>-0.015</sup> <sub>-0.051</sub>	3 <sup>+0.05</sup> <sub>0</sub>	7 <sup>+0.061</sup> <sub>+0.025</sub>	3 <sup>+0.5</sup> <sub>0</sub>
16	40	12 <sup>-0.018</sup> <sub>-0.061</sub>	3 <sup>+0.05</sup> <sub>0</sub>	10 <sup>+0.061</sup> <sub>+0.025</sub>	3.5 <sup>+0.5</sup> <sub>0</sub>
	20	12 <sup>-0.018</sup> <sub>-0.061</sub>	3 <sup>+0.05</sup> <sub>0</sub>	10 <sup>+0.061</sup> <sub>+0.025</sub>	3.5 <sup>+0.5</sup> <sub>0</sub>
20	50	14 <sup>-0.018</sup> <sub>-0.061</sub>	3.5 <sup>+0.05</sup> <sub>0</sub>	12 <sup>+0.075</sup> <sub>+0.032</sub>	3.5 <sup>+0.5</sup> <sub>0</sub>
	50	14 <sup>-0.018</sup> <sub>-0.061</sub>	3.5 <sup>+0.05</sup> <sub>0</sub>	12 <sup>+0.075</sup> <sub>+0.032</sub>	3.5 <sup>+0.5</sup> <sub>0</sub>
25	60	18 <sup>-0.018</sup> <sub>-0.061</sub>	4 <sup>+0.05</sup> <sub>0</sub>	15 <sup>+0.075</sup> <sub>+0.032</sub>	5 <sup>+0.5</sup> <sub>0</sub>

Unit [mm]

Size	Radial direction dimensions												Axial direction dimensions								
	A <sub>1</sub>	A <sub>2</sub>	A <sub>3</sub>	B	C <sub>1</sub>	C <sub>2</sub>	C <sub>3</sub>	F	V <sub>1</sub>	V <sub>2</sub>	V <sub>3</sub>	Y	Z	H	J	K	L	M	P	X	a
06	63	46	34.5	67.5	80	72	35	23	3-3.1	3-6.3	3-5.5	5	6-60°	24	3.5	2.1	28	22	7.3	2.5	0.2 ±0.05
08	80	60	41.7	85	100	90	42	28.5	3-4.1	3-8	3-7	6	6-60°	26.5	4.3	2.6	31	24	8.3	2.85	0.2 ±0.05
10	100	76	51.5	106	125	112	52	40	3-5.1	3-11	3-9	7	6-60°	30	5	3.1	36.1	27	9	3.3	0.2 ±0.05
12	125	95	61.5	133	150	137	62	45	3-6.1	3-12	3-11	7	6-60°	33.5	5.5	3.6	40.5	30	9.3	3.3	0.3 <sup>+0.05</sup> <sub>-0.1</sub>
16	160	120	79.5	169	190	175	80	62	3-8.2	3-15	3-14	9.5	6-60°	37.5	6	4.1	46.5	34	11.7	3.5	0.3 <sup>+0.05</sup> <sub>-0.1</sub>
20	200	158	99.5	212.3	230	215	100	77	3-10.2	3-18	3-16.2	9.5	6-60°	44	7	5.1	55.4	40	13.4	4.9	0.5 <sup>+0.05</sup> <sub>-0.2</sub>
25	250	210	124.5	264	290	270	125	100	4-12.2	4-22	4-20	11.5	8-45°	51	8	6.1	63.9	47	16	5.5	0.5 <sup>+0.05</sup> <sub>-0.2</sub>

\* For details on mounting method, see "Items Checked for Design Purposes".

How to Place an Order

101-06-13G 24V 12DIN

Size

Keyway standards DIN: Compliant with JIS standards P9  
 JIS: Compliant with the old JIS standards (class 2) E9  
 Rotor bore diameter (dimensional symbol d)

## Dimensions (101-□-15G)

(For through-shafts)

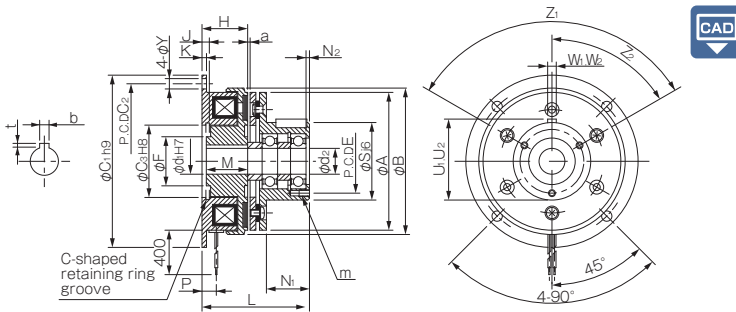

Unit [mm]

Size	Shaft bore dimensions							
	d <sub>1</sub> H7	d <sub>2</sub>	Models compliant with JIS standards				Models compliant with the old JIS standards	
			b p9	t	b E9	t		
06	12	12	4	1.5	4	1.5	1.5	0
08	15	15	5	2	5	2	2	0
10	20	20	6	2.5	5	2	2	0
12	25	25	8	3	7	3	3	0
16	30	30	8	3	7	3	3	0
20	40	40	12	3	10	3.5	3.5	0
25	50	50	14	3.5	12	3.5	3.5	0

Unit [mm]

Size	Radial direction dimensions										Axial direction dimensions														
	A	B	C <sub>1</sub>	C <sub>2</sub>	C <sub>3</sub>	E	F	Y	S	Z <sub>1</sub>	Z <sub>2</sub>	H	J	K	L	M	N <sub>1</sub>	N <sub>2</sub>	P	U <sub>1</sub>	W <sub>1</sub>	U <sub>2</sub>	W <sub>2</sub>	a	m
06	63	67.5	80	72	35	33	23	5	38	3-120°	60°	24	3.5	2.1	51.5	22	20	2	7.3	39.5	4	39.5	4	0.2 ±0.05	3-M4 × 0.7, length: 4
08	80	85	100	90	42	37	28.5	6	45	3-120°	60°	26.5	4.3	2.6	60	24	25	2	8.3	47	5	47	5	0.2 ±0.05	3-M4 × 0.7, length: 6
10	100	106	125	112	52	47	40	7	55	4-90°	45°	30	5	3.1	71.1	27	30	3	9	57	5	57.5	6	0.2 ±0.05	4-M4 × 0.7, length: 8
12	125	133	150	137	62	52	45	7	64	4-90°	45°	33.5	5.5	3.6	86.5	30	40	2.2	9.3	67	7	67	8	0.3 ±0.05	4-M4 × 0.7, length: 8
16	160	169	190	175	80	62	62	9.5	75	6-60°	30°	37.5	6	4.1	103.5	34	50	3	11.7	78	7	78	8	0.3 ±0.05	6-M5 × 0.8, length: 8
20	200	212.3	230	215	100	74.5	77	9.5	90	4-90°	45°	44	7	5.1	124.4	40	60	5	13.4	93.5	10	93	10	0.5 ±0.2	4-M6 × 1, length: 12
25	250	264	290	270	125	101.5	100	11.5	115	8-45°	22.5°	51	8	6.1	144.9	47	70	6	16	118.5	12	118	12	0.5 ±0.2	8-M6 × 1, length: 12

\* For details on mounting method, see "Items Checked for Design Purposes".

### How to Place an Order

101-06-15G 24V R12DIN A12JIS

Size  
 Rotor bore diameter (dimensional symbol d1)  
 Keyway standards DIN: Compliant with JIS standards P9  
 JIS: Compliant with the old JIS standards (class 2) E9  
 Armature type-5 keyway standards  
 Dimensional symbol U2, W2: DIN: Compliant with JIS standards P9  
 Dimensional symbol U1, W1: JIS: Compliant with the old JIS standards (class 2) E9  
 Armature bore diameter (dimensional symbol d2)

## Dimensions (101-□-11G)

(For butt shafts)

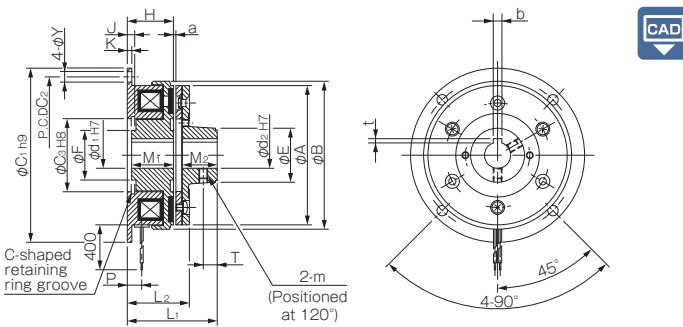

Unit [mm]

Size	Shaft bore dimensions							
	d <sub>1</sub> H7	d <sub>2</sub> H7	Models compliant with JIS standards				Models compliant with the old JIS standards	
			b p9	t	b E9	t		
06	12	12	4	1.5	4	1.5	1.5	0
	15	15	5	2	5	2	2	0
08	15	15	5	2	5	2	2	0
	20	20	6	2.5	5	2	2	0
10	20	20	6	2.5	5	2	2	0
	25	25	8	3	7	3	3	0
12	25	25	8	3	7	3	3	0
	30	30	8	3	7	3	3	0
16	30	30	8	3	7	3	3	0
	40	40	12	3	10	3.5	3.5	0
20	40	40	12	3	10	3.5	3.5	0
	50	50	14	3.5	12	3.5	3.5	0
25	50	50	14	3.5	12	3.5	3.5	0
	60	60	18	4	15	4	4	0

Unit [mm]

Size	Radial direction dimensions										Axial direction dimensions									
	A	B	C <sub>1</sub>	C <sub>2</sub>	C <sub>3</sub>	E	F	Y	m	H	J	K	L <sub>1</sub>	L <sub>2</sub>	M <sub>1</sub>	M <sub>2</sub>	P	T	a	
06	63	67.5	80	72	35	26	23	5	M4	24	3.5	2.1	43	31.5	22	15	7.3	6	0.2 ±0.05	
08	80	85	100	90	42	31	28.5	6	M5	26.5	4.3	2.6	51	35	24	20	8.3	8	0.2 ±0.05	
10	100	106	125	112	52	41	40	7	M5	30	5	3.1	61.1	41.1	27	25	9	10	0.2 ±0.05	
12	125	133	150	137	62	49	45	7	M6	33.5	5.5	3.6	70.5	46.5	30	30	9.3	12	0.3 ±0.05	
16	160	169	190	175	80	65	62	9.5	M8	37.5	6	4.1	84.5	53.5	34	38	11.7	15	0.3 ±0.05	
20	200	212.3	230	215	100	83	77	9.5	M8	44	7	5.1	100.4	64.4	40	45	13.4	18	0.5 ±0.2	
25	250	264	290	270	125	105	100	11.5	M10	51	8	6.1	118	75	47	54	16	22	0.5 ±0.2	

\* For details on mounting method, see "Items Checked for Design Purposes".

### How to Place an Order

101-06-11G 24V R12DIN A12DIN

Size  
 Rotor bore diameter (dimensional symbol d1)  
 Keyway standards DIN: Compliant with JIS standards P9  
 JIS: Compliant with the old JIS standards (class 2) E9  
 Armature bore diameter (dimensional symbol d2)  
 Keyway standards DIN: Compliant with JIS standards P9  
 JIS: Compliant with the old JIS standards (class 2) E9